

Electric Windows – How do I wire?

You have gotten to the point where you think that you would like to wire your electric windows yourself, but you don't really know where to begin. Well the good news is that you have options.

You decide that you really don't like the normal window switches that are available, and that you want to use those fancy billet aluminum ones. The problem that you are faced with is that usually the billet switches are on-off-on switches, and are only rated for 5 amps. Want to fry an expensive billet switch? Wire it without a relay and you will. Here is what you need to do:

You will need to have 2 relays for each window function (up and down) and the switches must be momentary on-off-on.

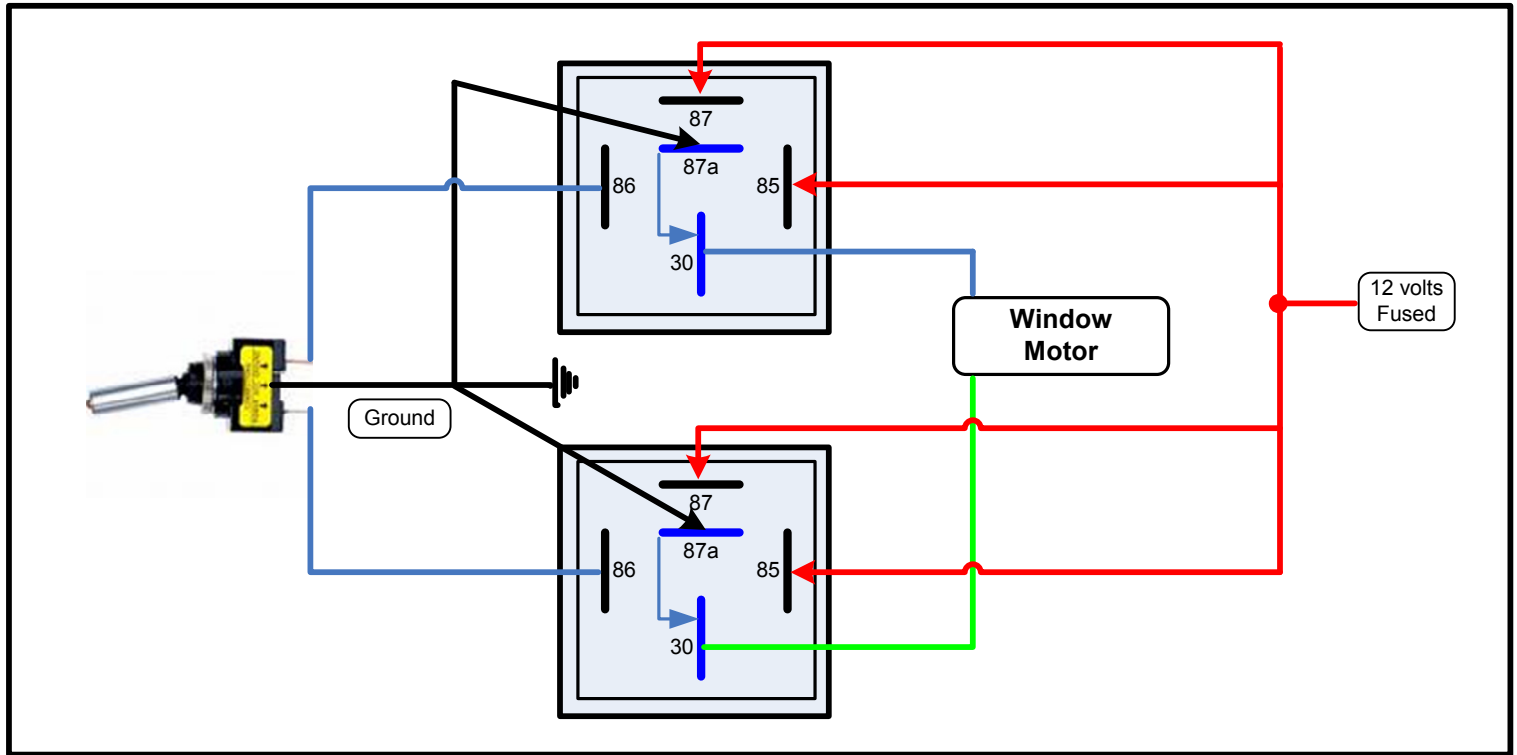

You may look at the diagram above and think that it looks very confusing. It could be until you break it down. It is easier to wire the circuit, than it is to diagram it. Here's the break down:

Think back at the diagram on the SPDT relay. The un-switched (unlatched) path is on posts 30 and 87a. By passing a + and - on posts 86 and 85 the path is "switched" to 30 and 87. (87a becomes an "open" circuit). In this example, we will change the path to go the opposite direction. Instead of the circuit passing from 30 to 87a or 87, we will be passing from 87a or 87 to 30. Still with me? Hope so, it's not as difficult as it seems. Now for how this works.

Switch – This is what got you into this situation in the first place. You had to have a switch that wasn't rated to power the window motor. The switch will be connected to a good ground. When you press the switch in either direction, a ground will be passed to one of the relays to cause it to latch.

Relays – In the normal state, (unlatched / un-switched), the relays will pass a ground to the motor from post 87a to the outbound post 30. When not switched, a ground will be present on both sides of the window motor. When you press the button / switch, you will send a ground to post 86 of the relay to cause it to latch / switch. This will cause the 12v waiting at post 87 to pass to the outbound post 30 and off to one side of the motor causing it to spin in a given direction.

Hint: Label each switch and relay as to their function. This will make life easier if you have a relay go bad at some time.

The StreetRod Store LLC does not warrant or guarantee this installation. It is the responsibility of the installer / owner to test functionality and assumes all responsibility.

Written by: The StreetRod Store LLC – www.thestreetrodstore.com